

TRAVELLER SPINNING WHEEL SINGLE DRIVE

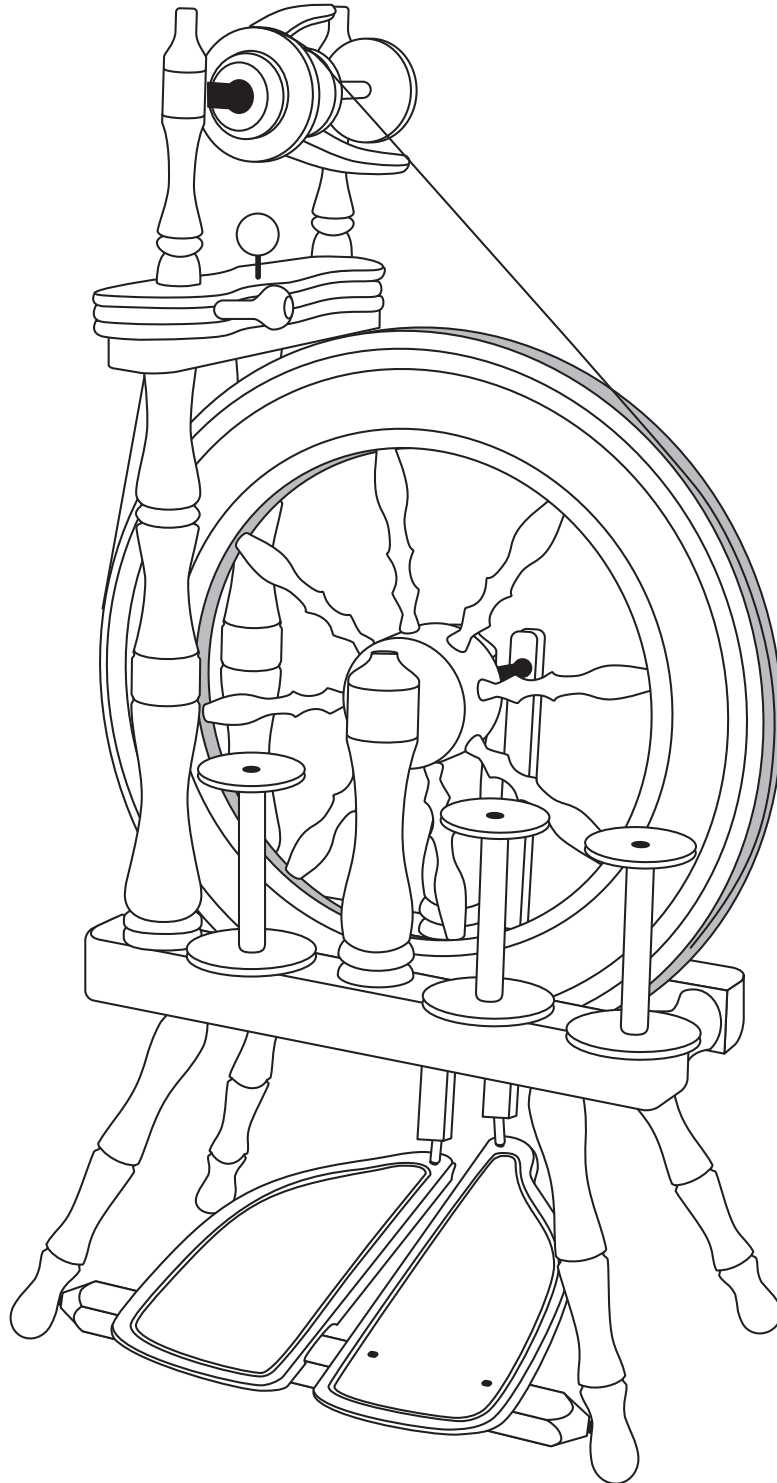

TVDTS20072010V4

TOOLS

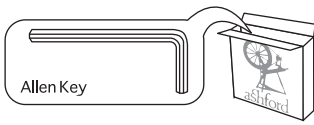
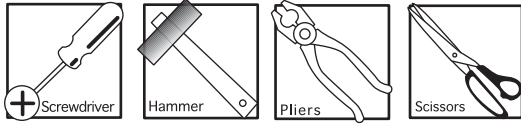

Hint 1

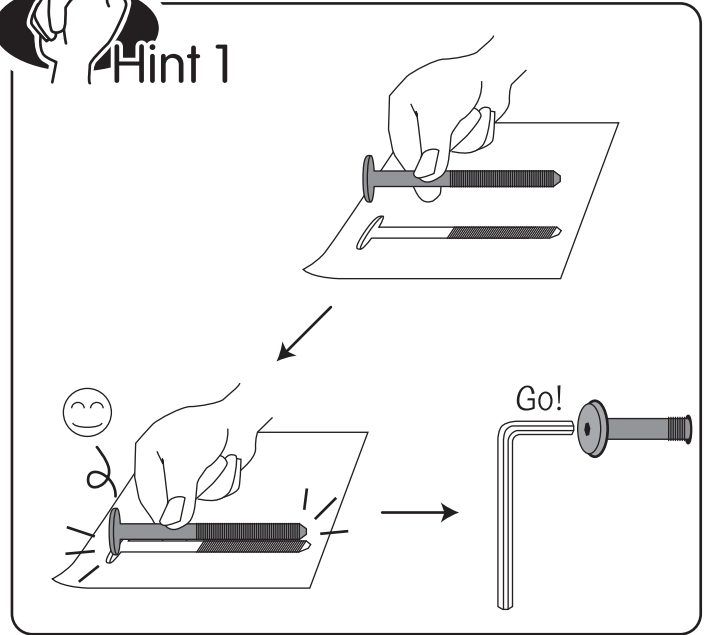

Hint 2

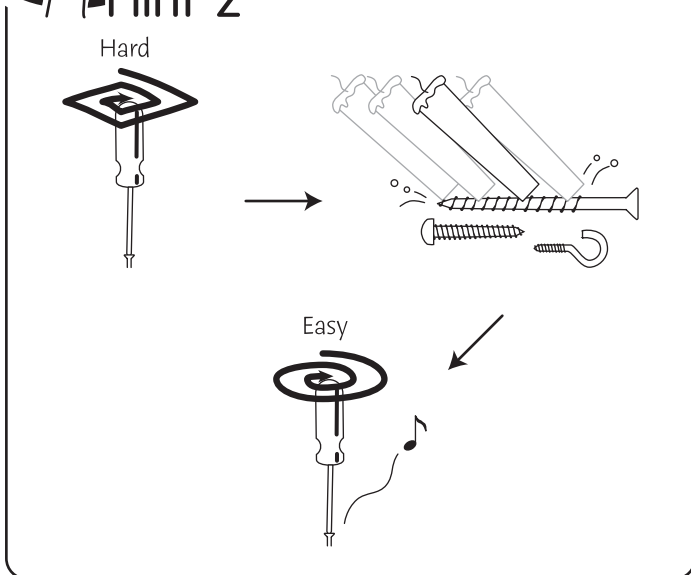

Hint 3

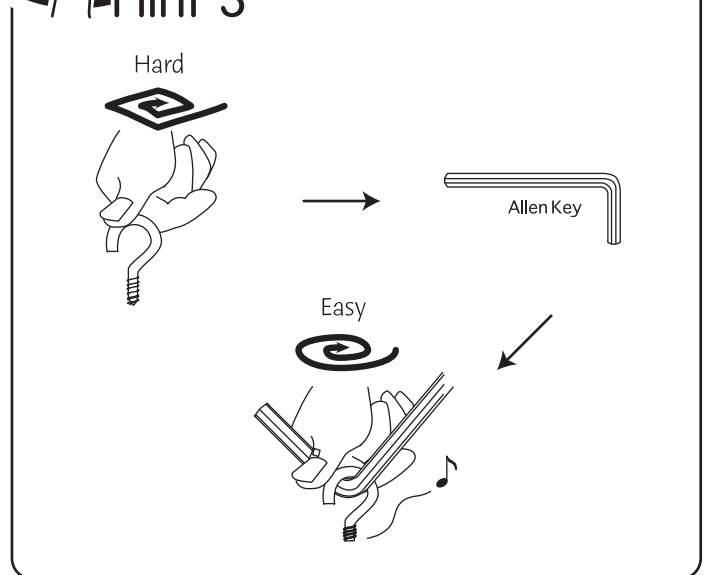

Carefully unpack the Product making sure you keep all the packing material until all the parts of the Product have been found and the Product has been assembled.

Please read these instructions and identify all parts before starting to assemble.

Traveller Single Drive Spinning Wheel - Hardware List



X2



X2



X2



X2



X4



X4



X2

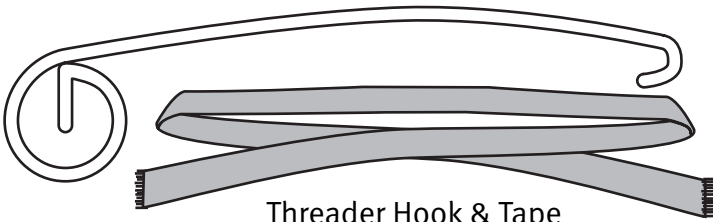

Threader Hook & Tape



1 X Hub Pin

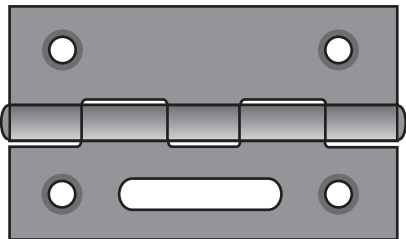

2 X Hinges



3 X Steel Lazy Kate Pins



1 X Drawing Pin



13 X Cup Hooks



1 x Screw Eye



2 X Tension Springs



1 X "O" Clip

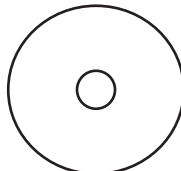

2 X Metal Washer



1 X Nylon Washer

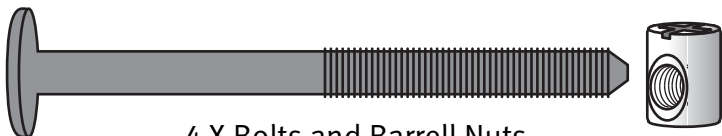

4 X Bolts and Barrell Nuts



2 X Flexible Conrod Joint

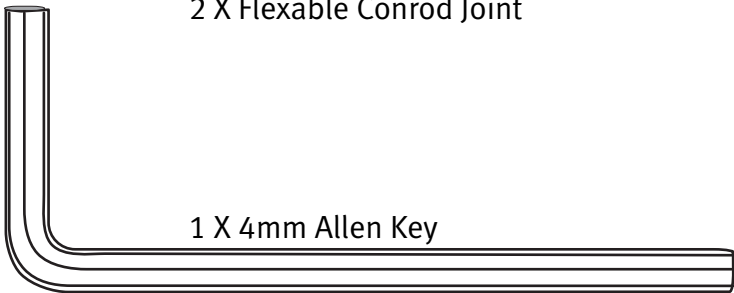

1 X 4mm Allen Key

1 X Double Drive Band

1 X Nylon Brake Band

Traveller Single Drive Spinning Wheel - Parts List

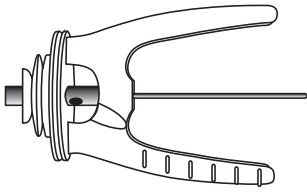

Flyer



Maiden Bar

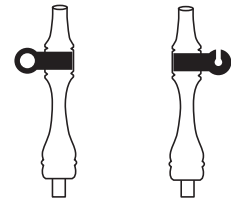

Maid Uprights



Adjusting Knob



Tension Knob

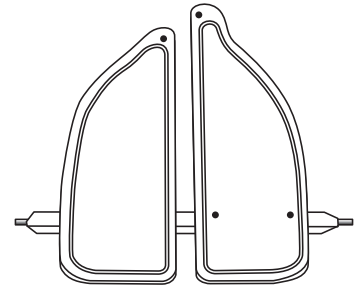

Treadle Assembly

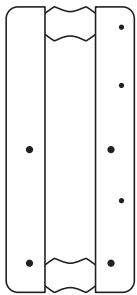

Base

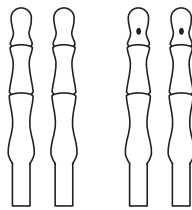

Legs - 2 with holes
& 2 without

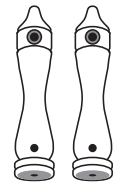

Wheel Supports

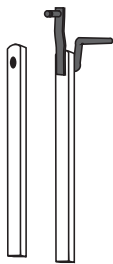

Conrods

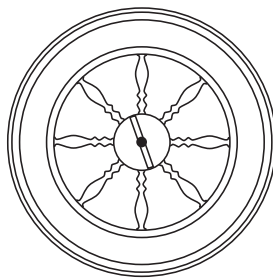

Wheel



Maiden Bar Supports



Top Rail

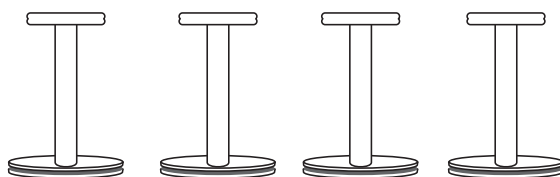

4 X Bobbins

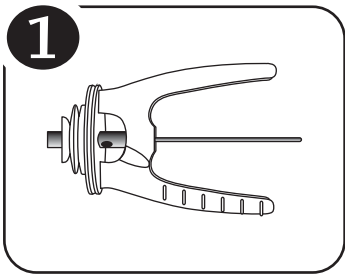

X12

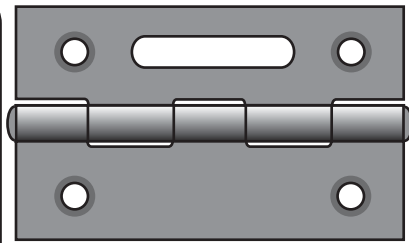
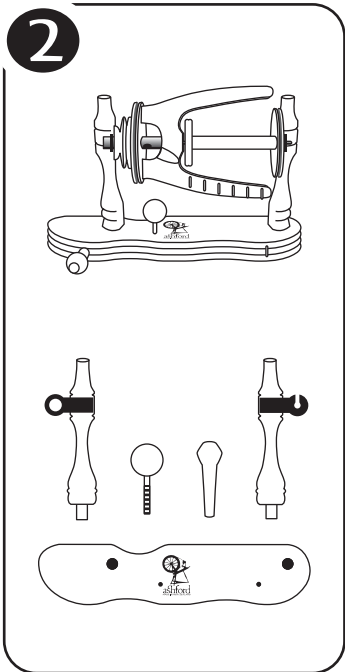
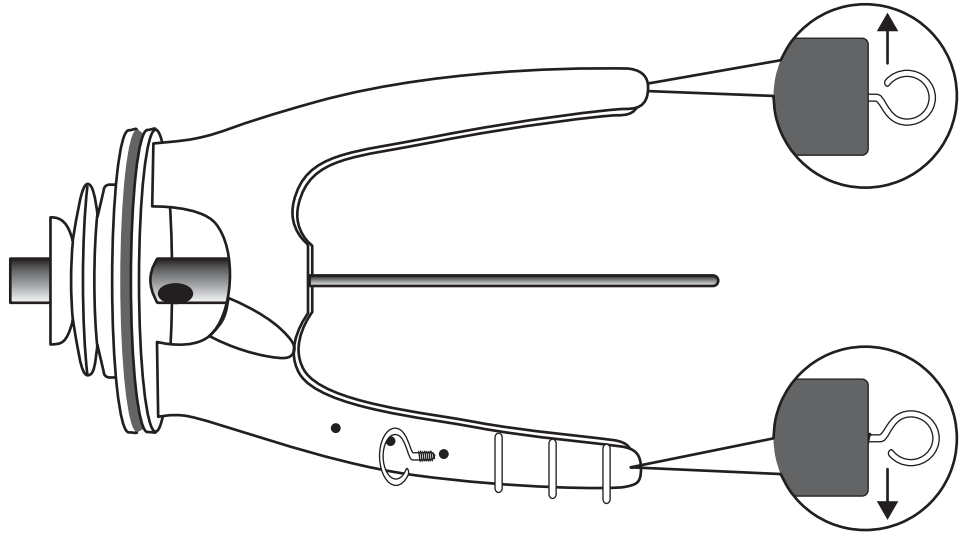

X2



X4

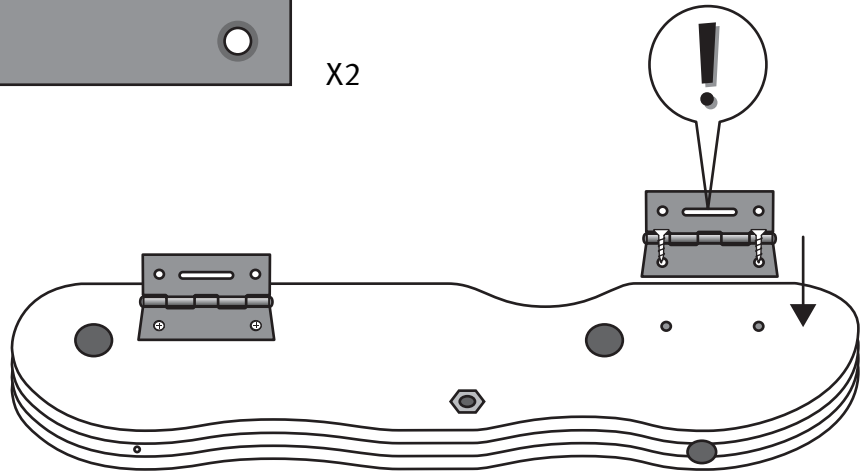

4

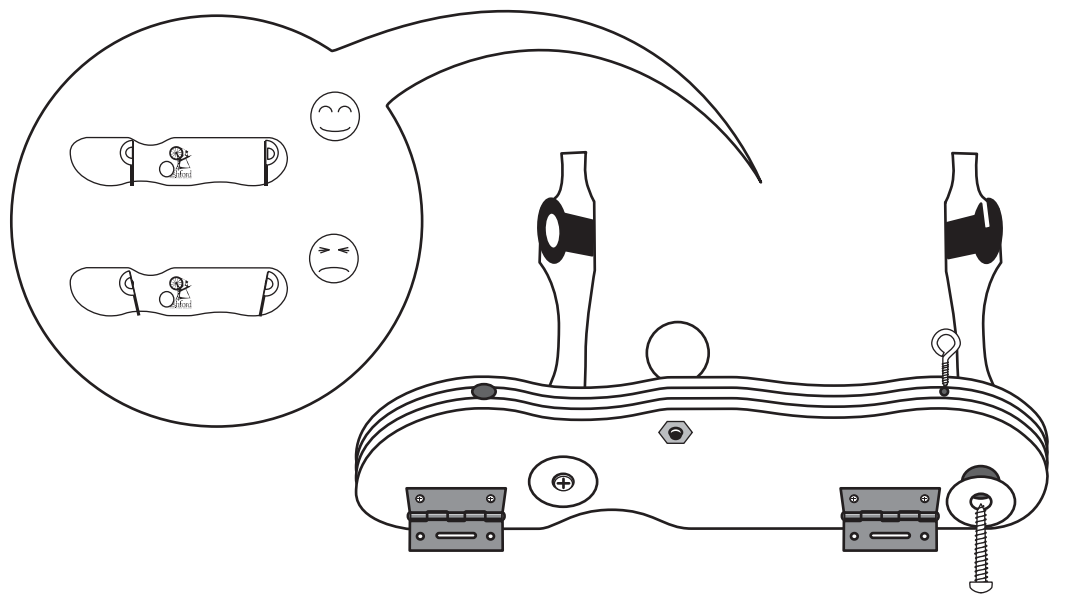
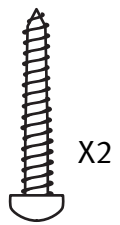
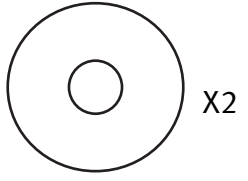

5

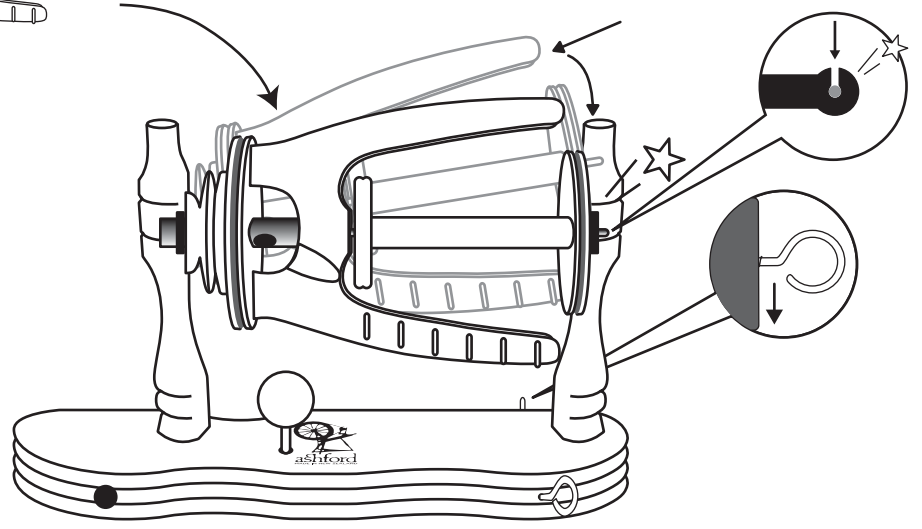
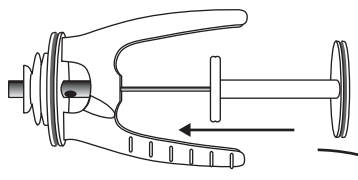

6

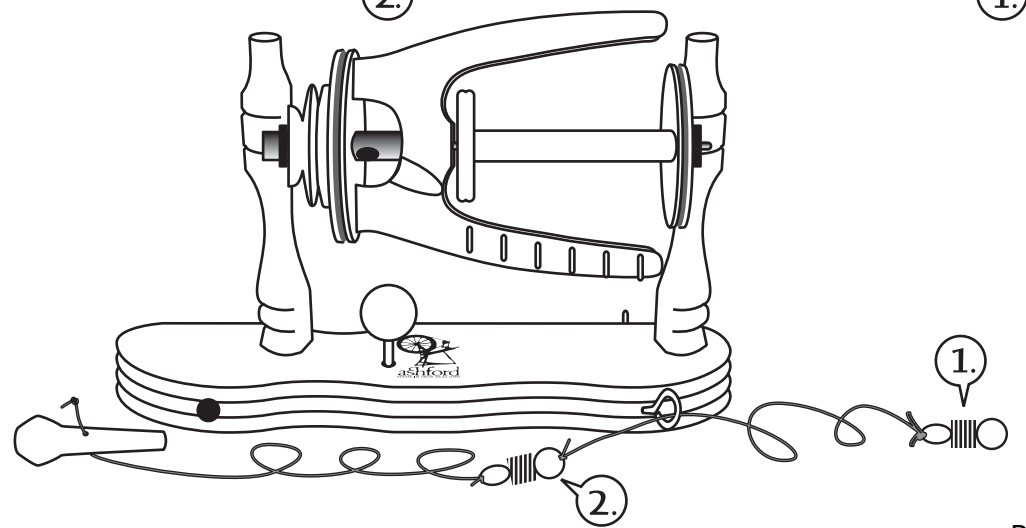
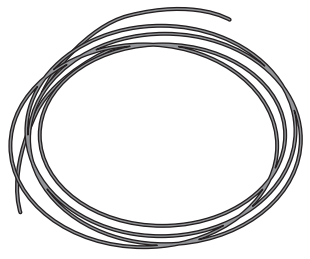
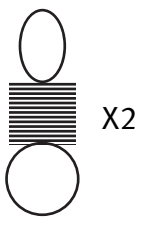
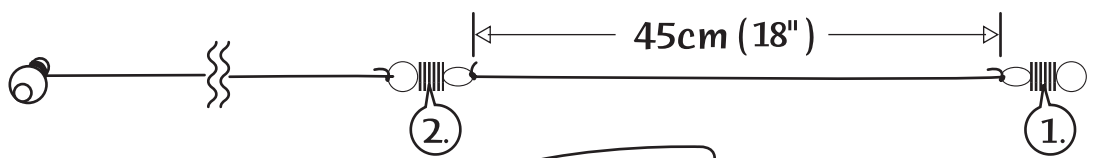

7

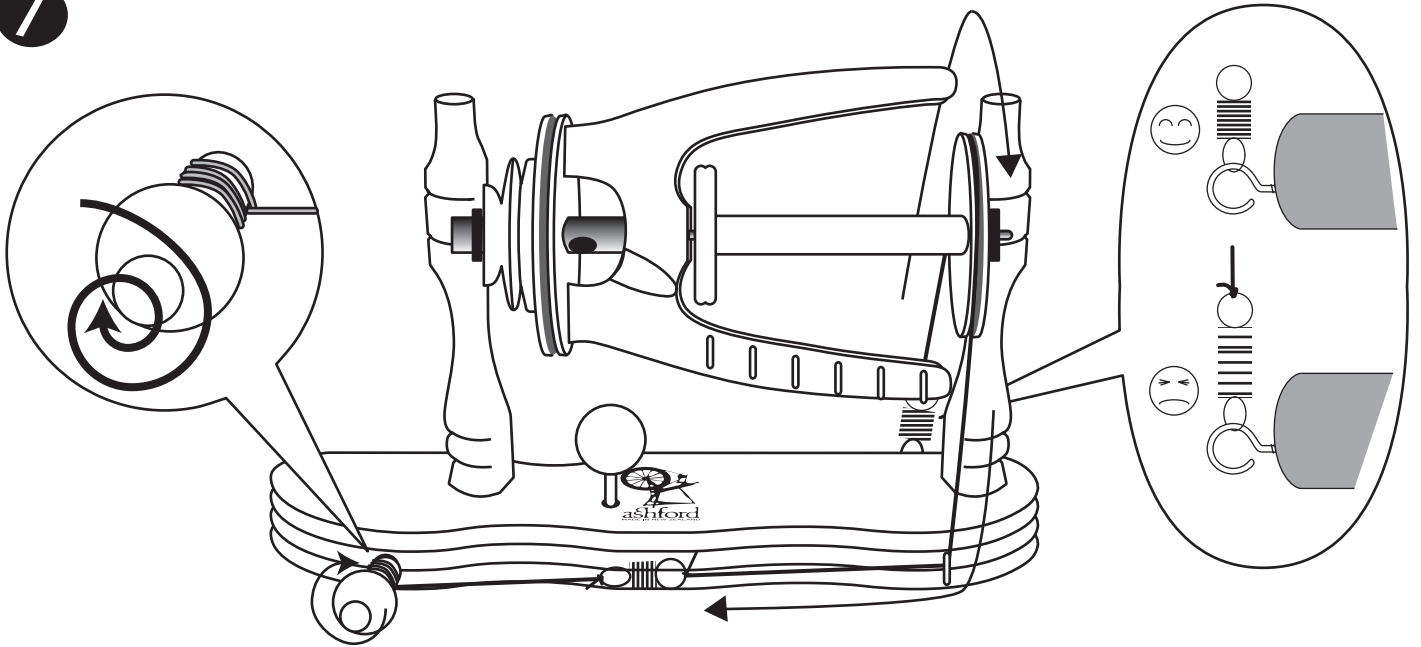

8

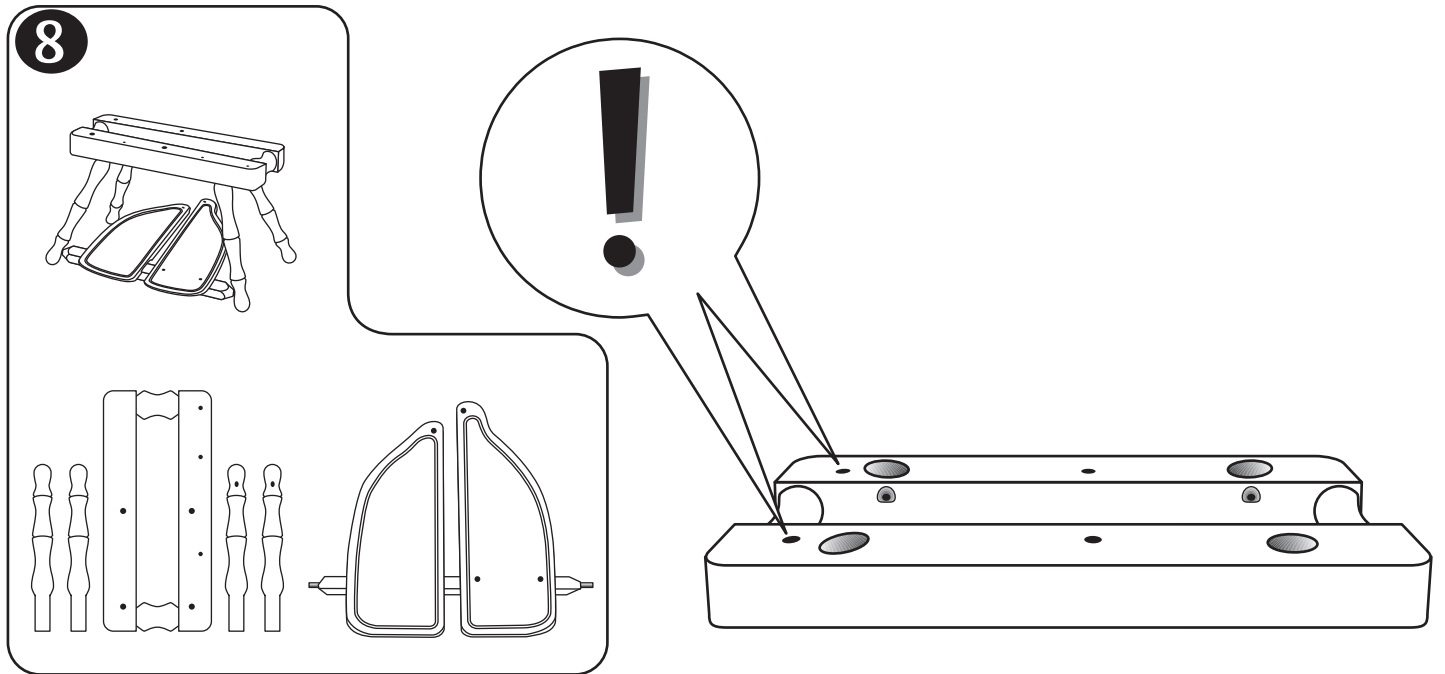

9

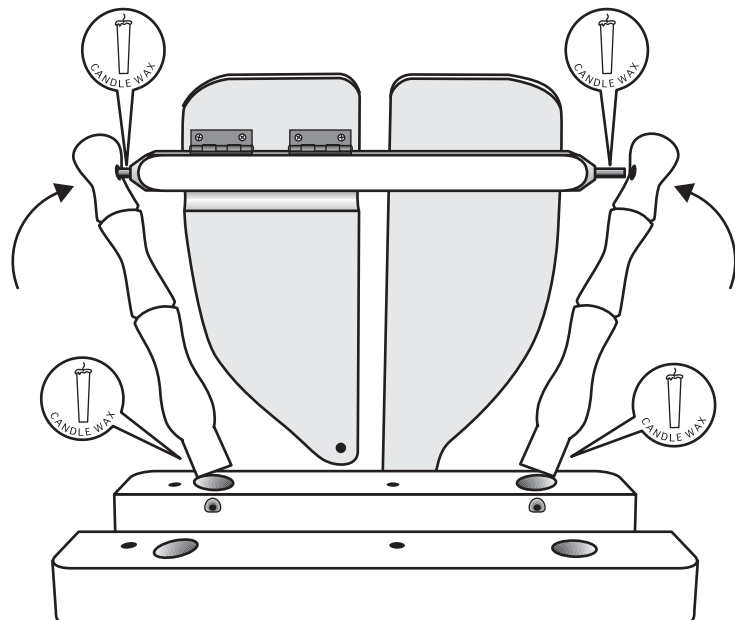

10

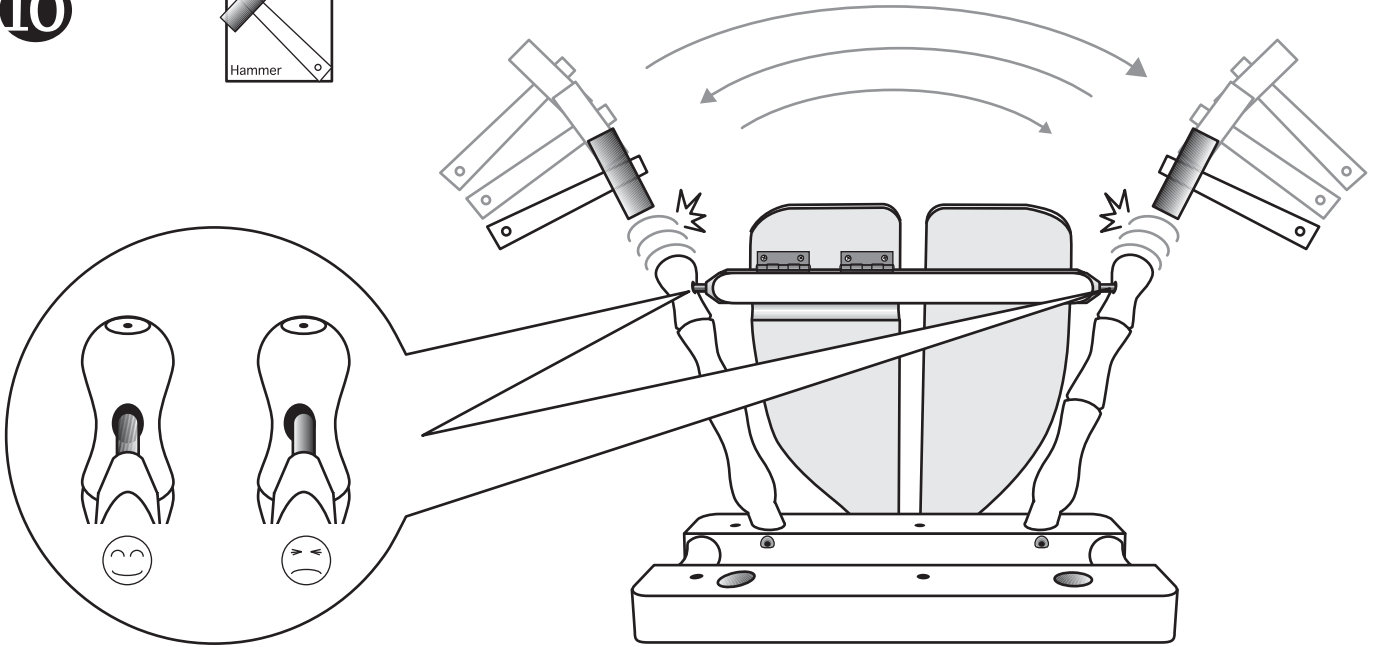
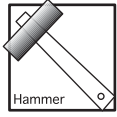

11

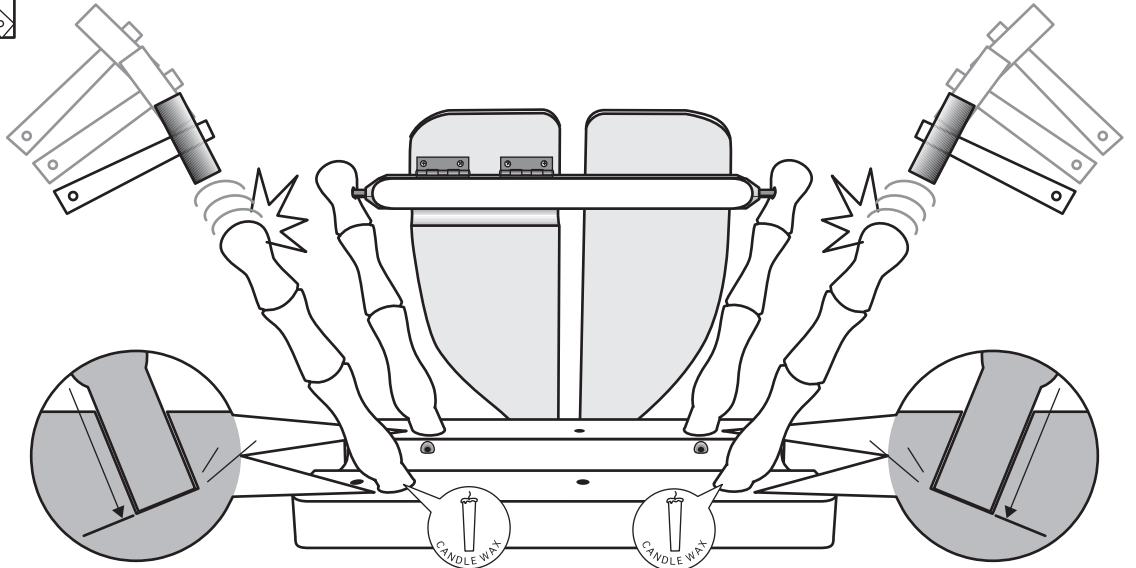
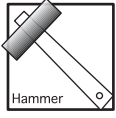

12



X4

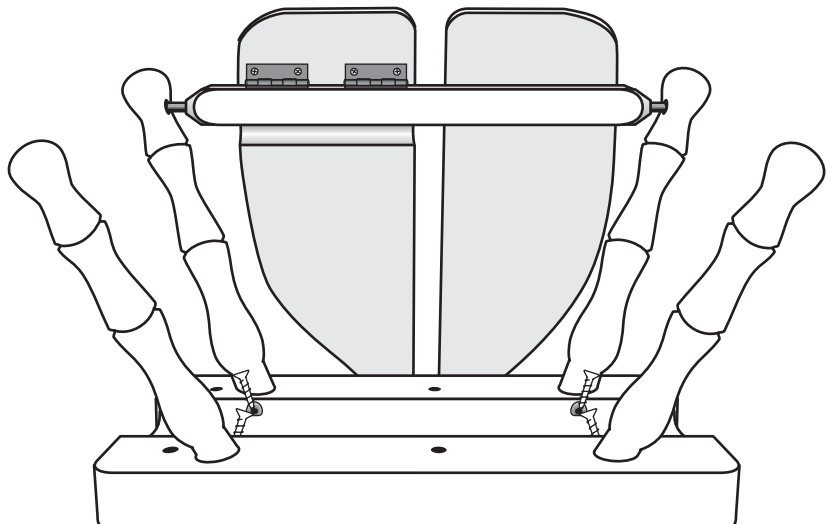

13

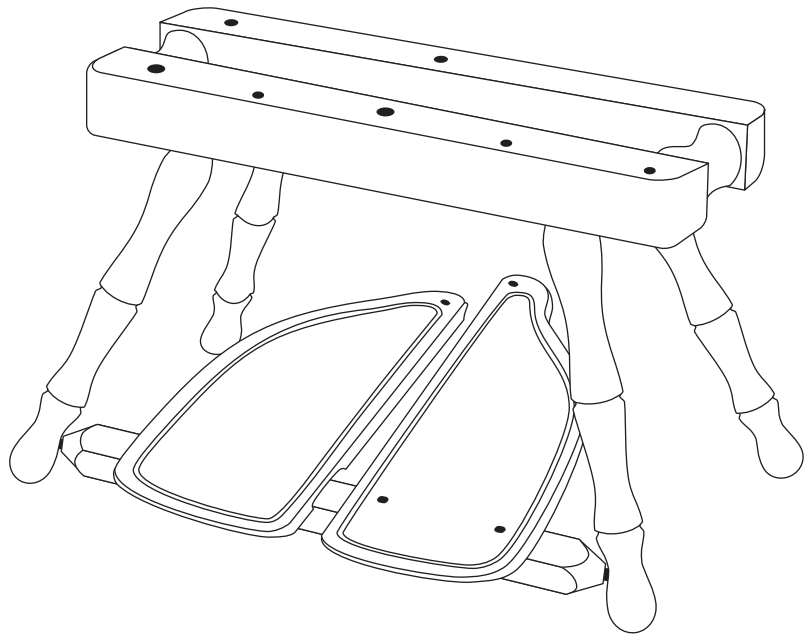

14

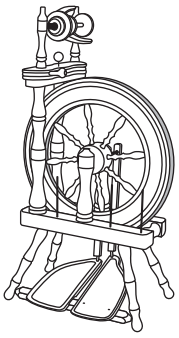

 *check*

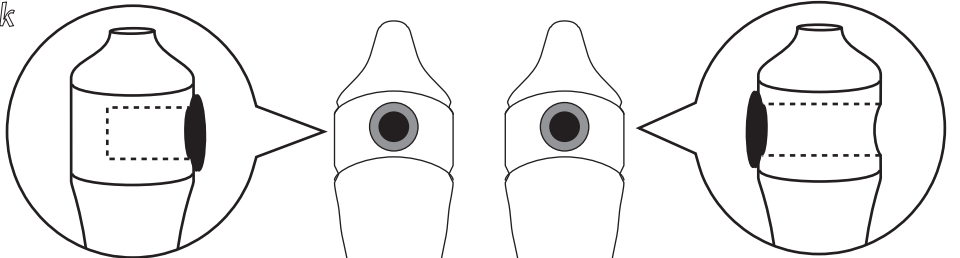

15

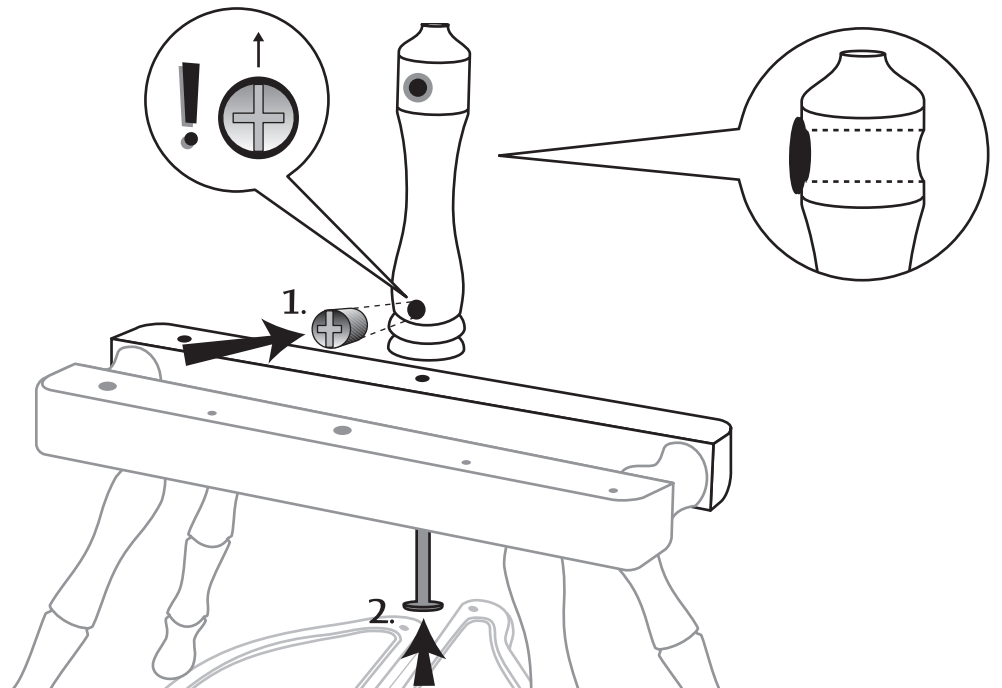
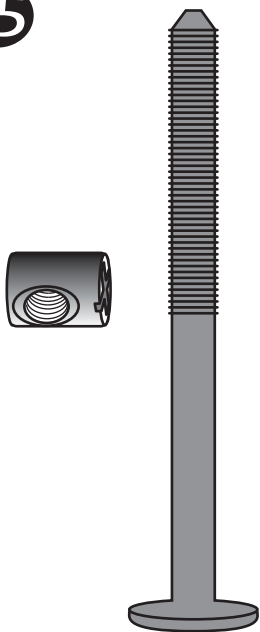

16

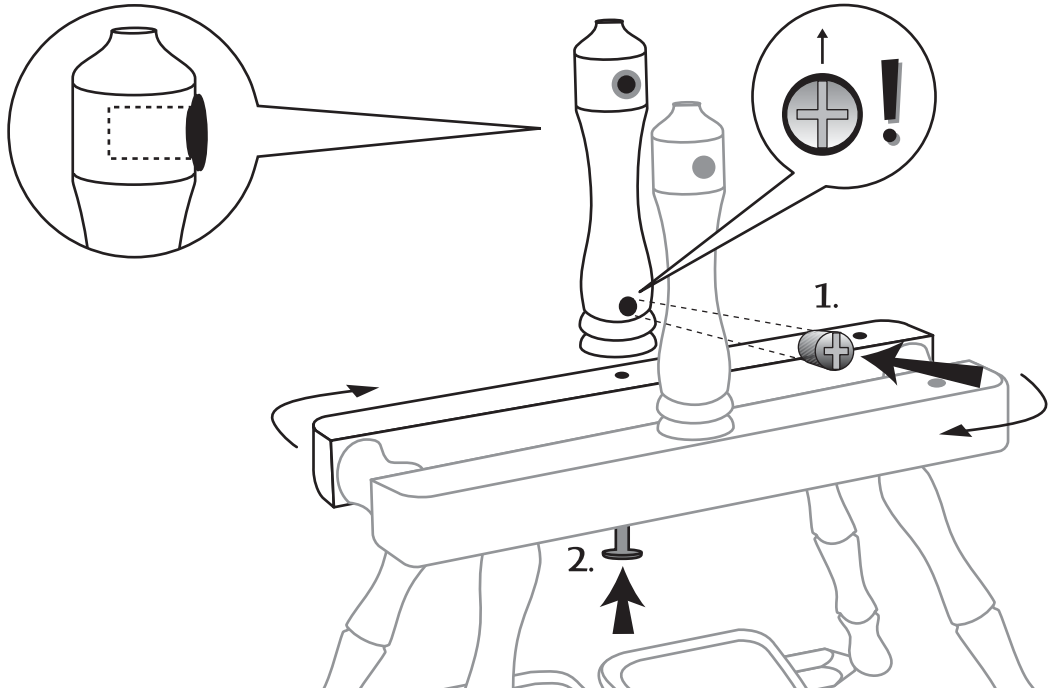
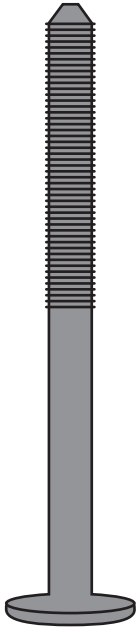

17

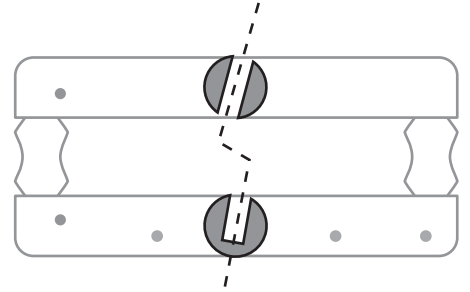
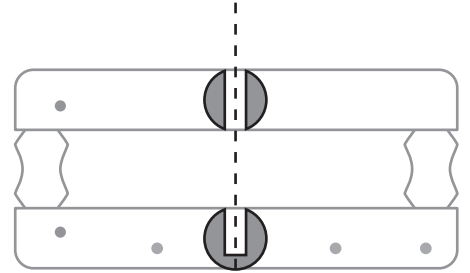
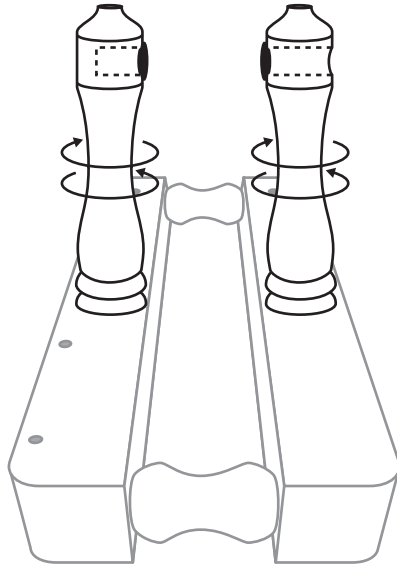

18



Allen Key

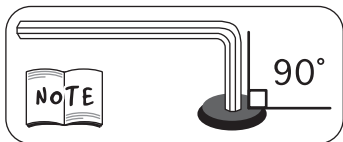
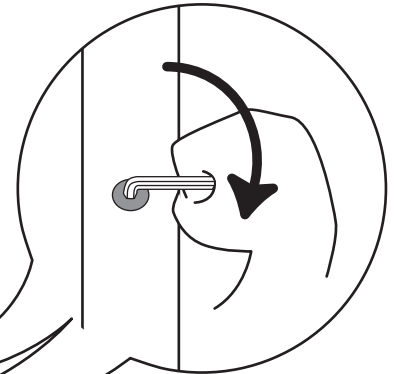
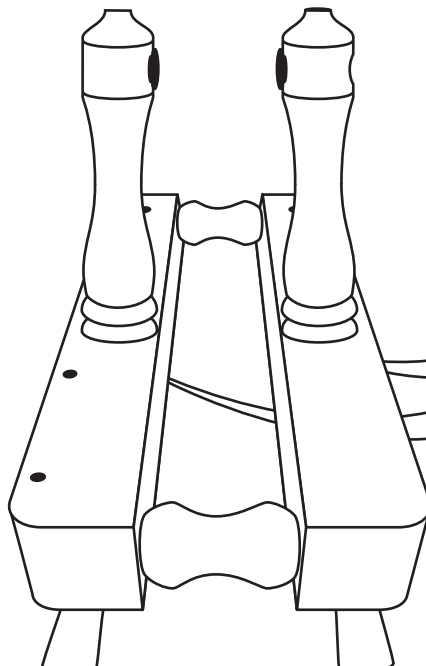

19



X2

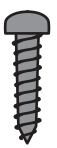

X2

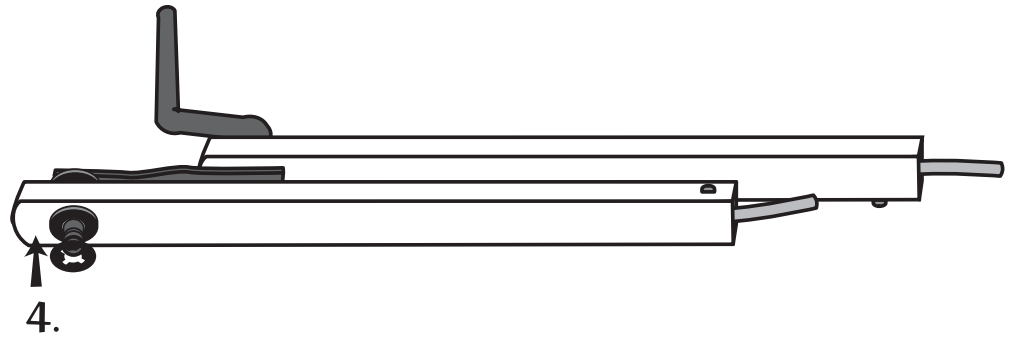
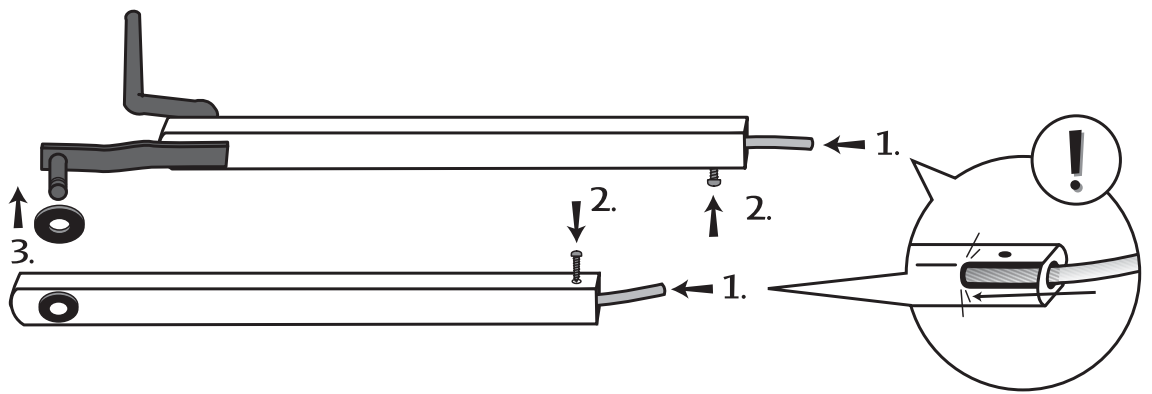

20

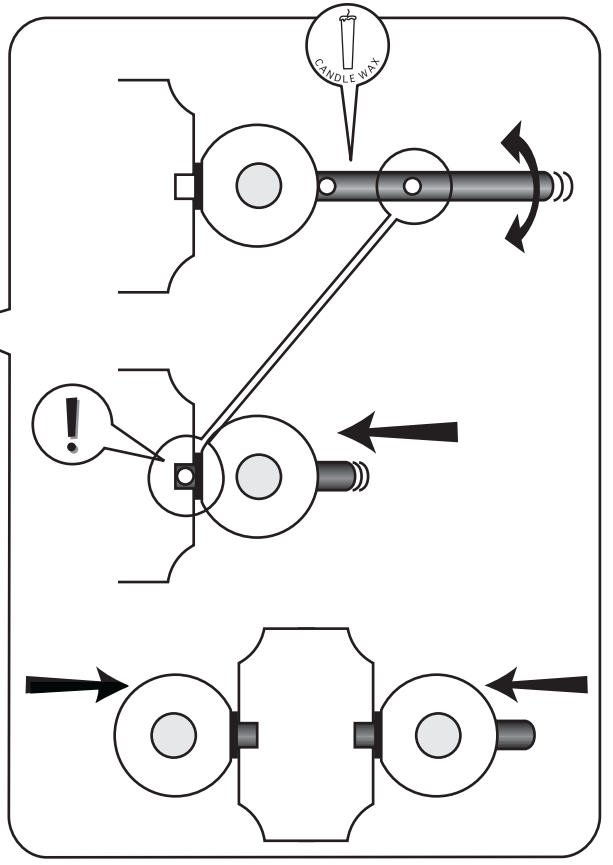
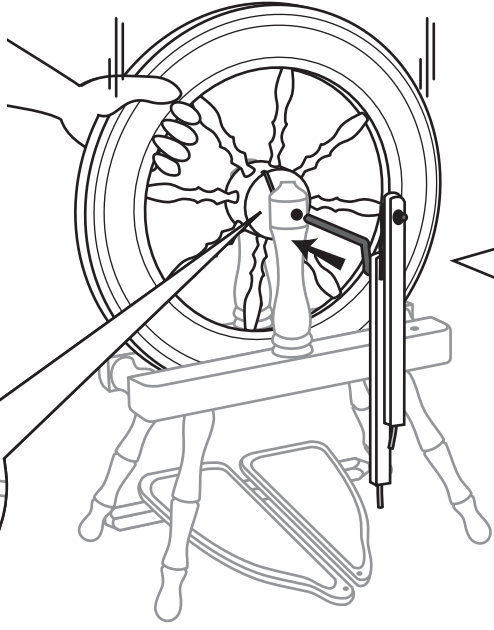
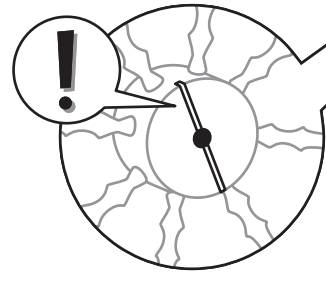

21

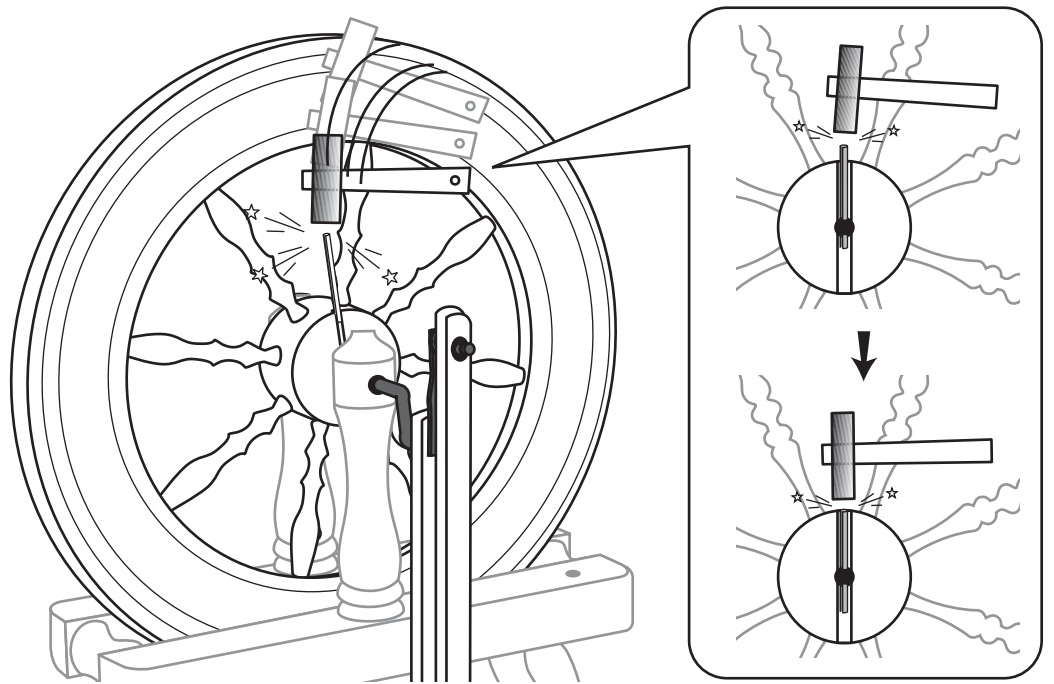
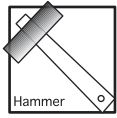

22

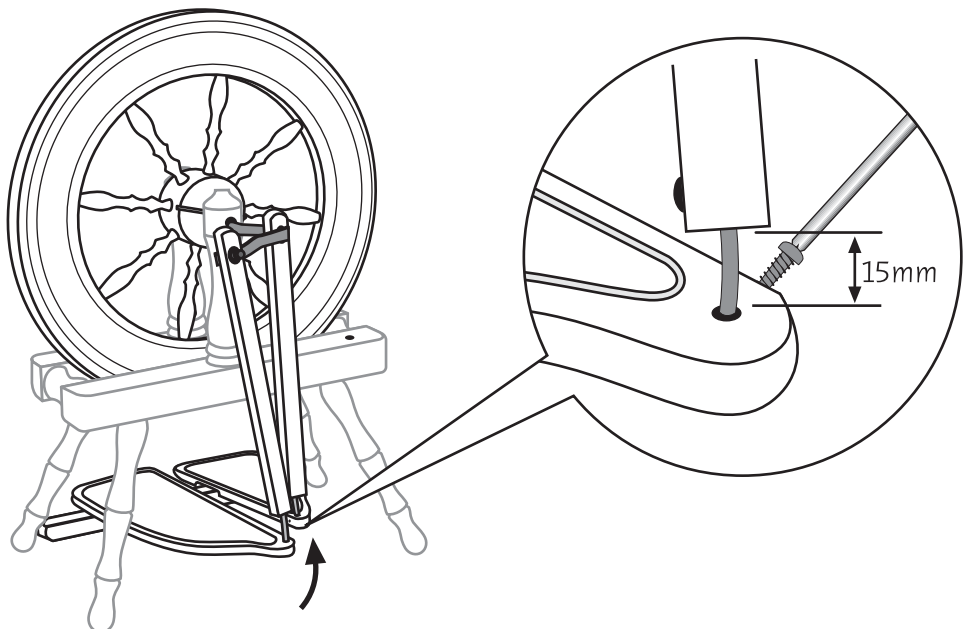
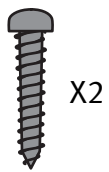
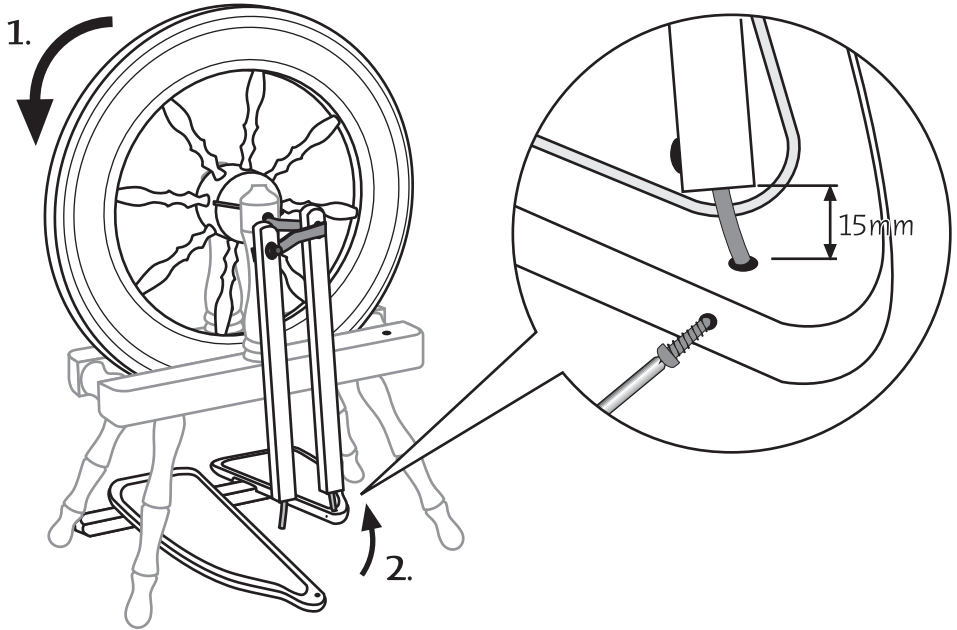

23

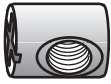

X2

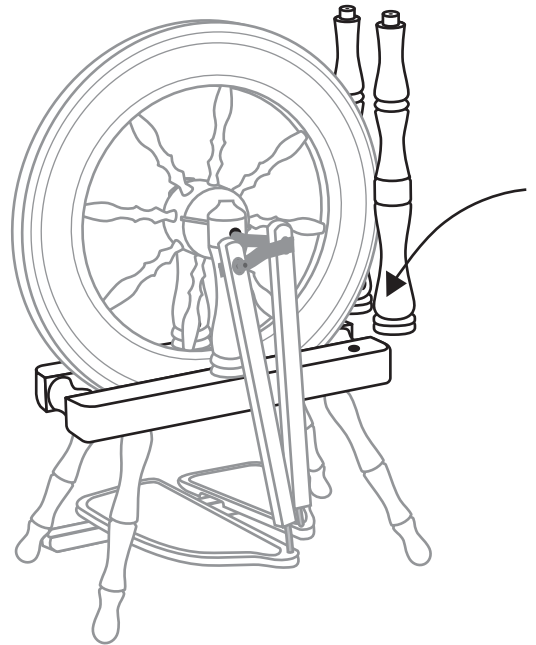
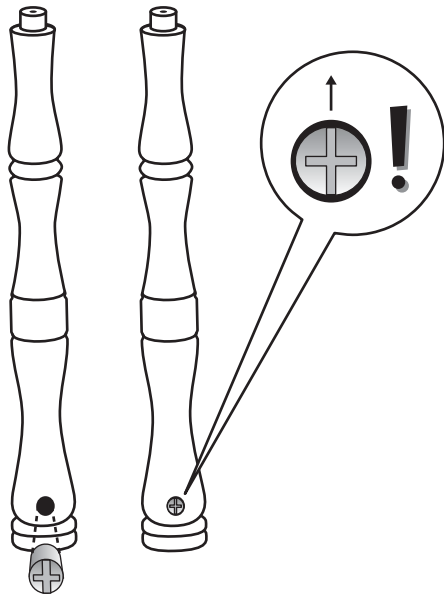

24

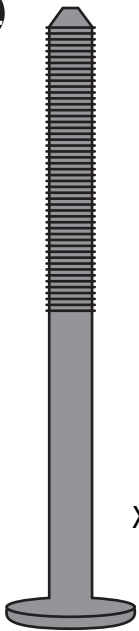

X2



Allen Key

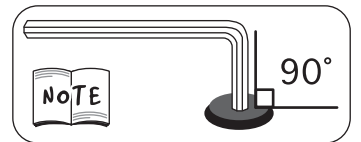
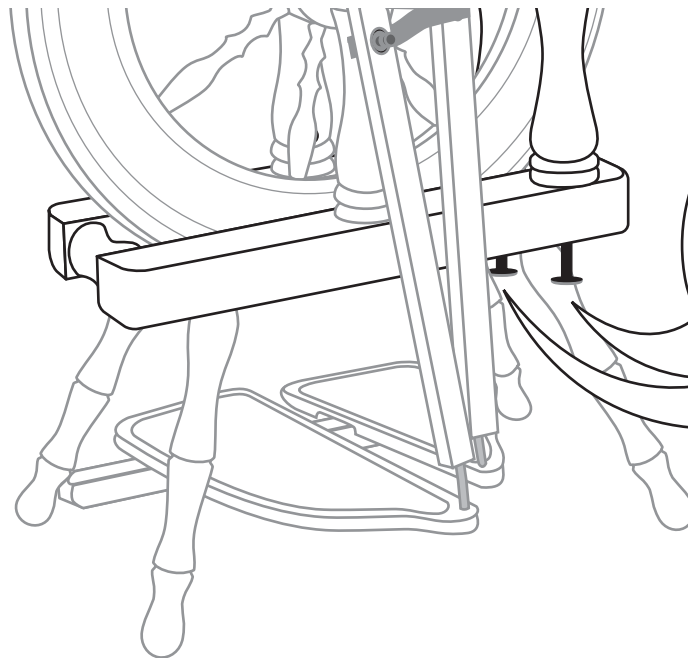

NOTE

90°

25



CANDLE WAX



Screwdriver

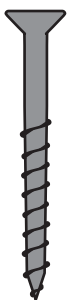

X2

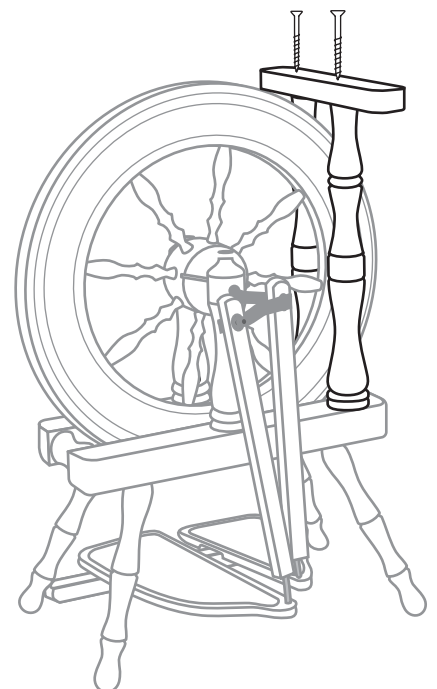
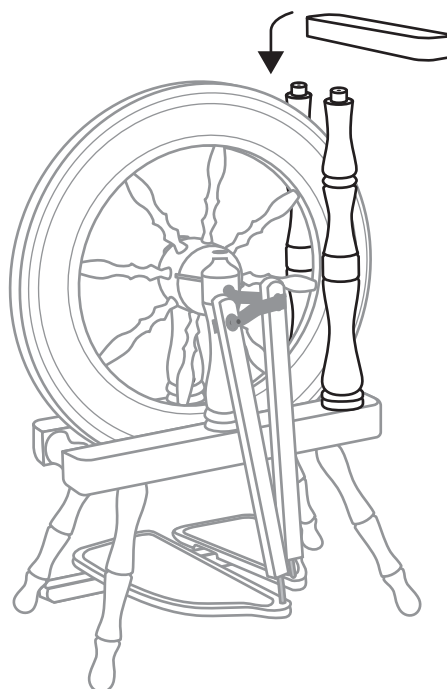

26

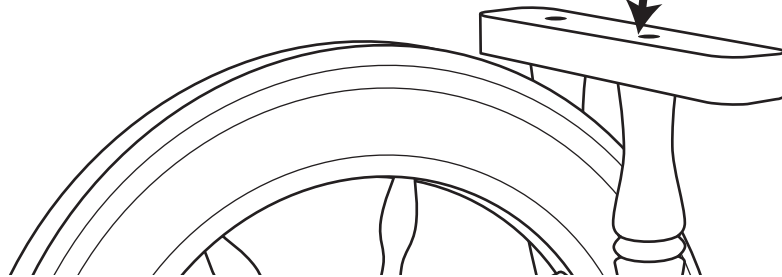
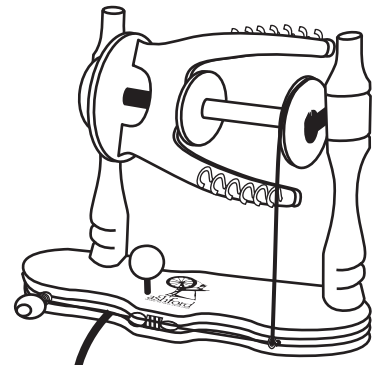

X2

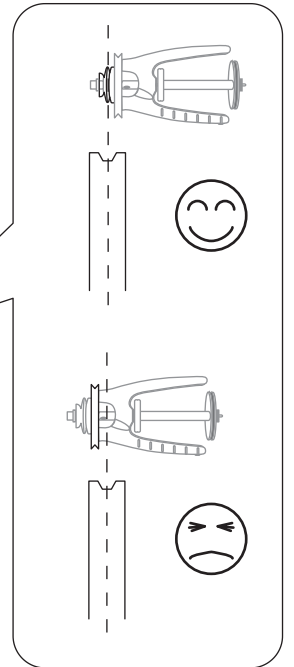
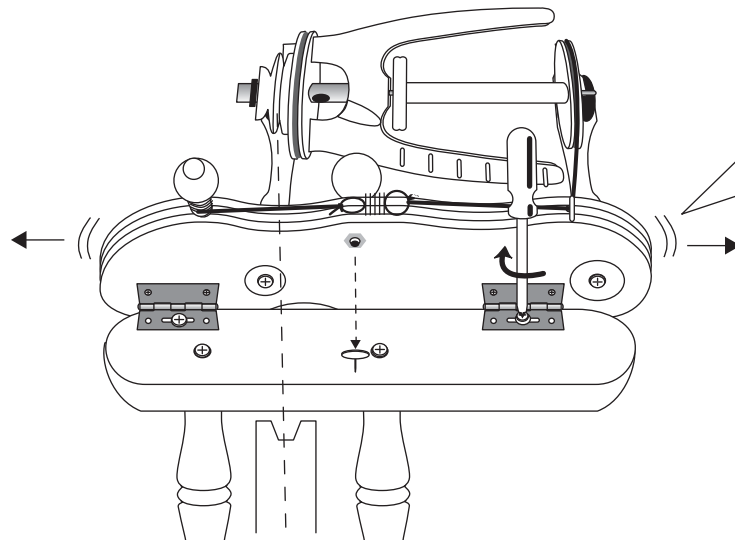

27

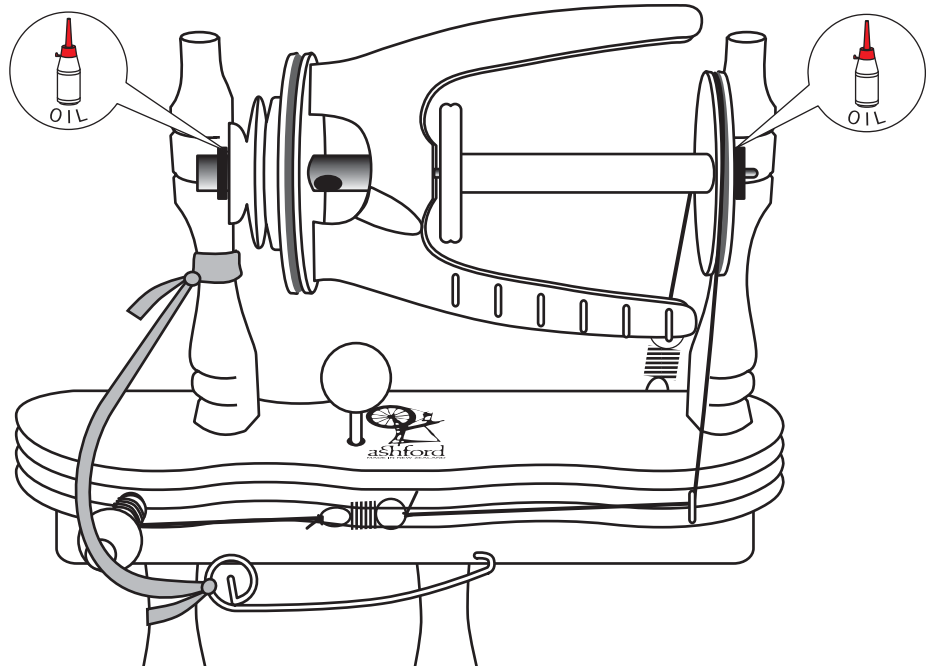
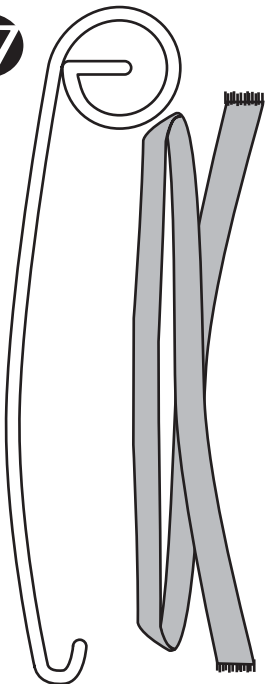

28

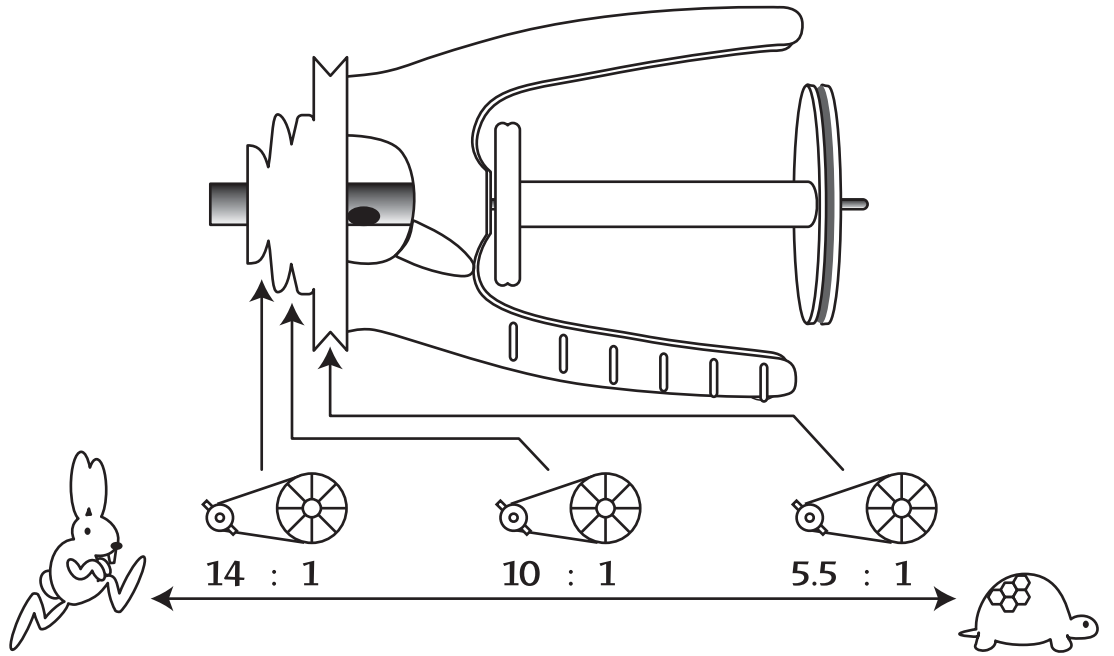
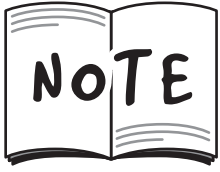

29

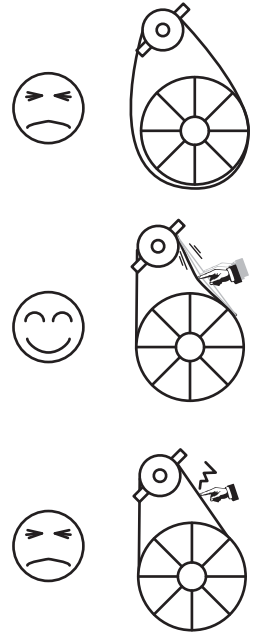
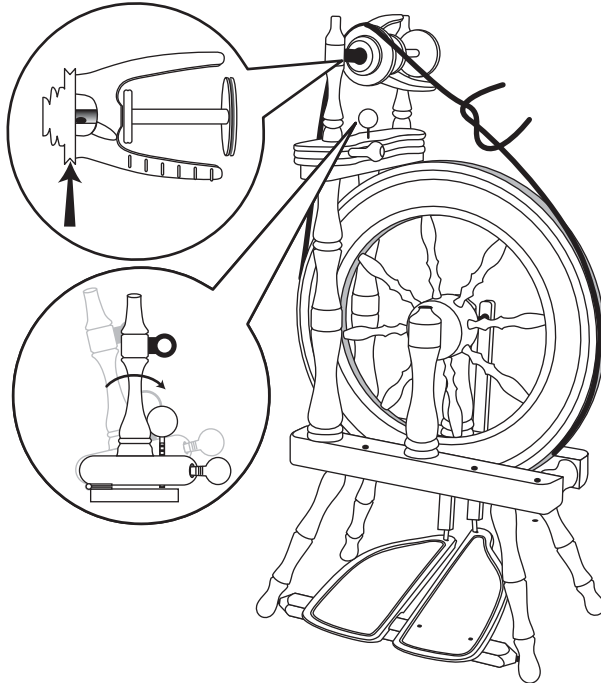

30

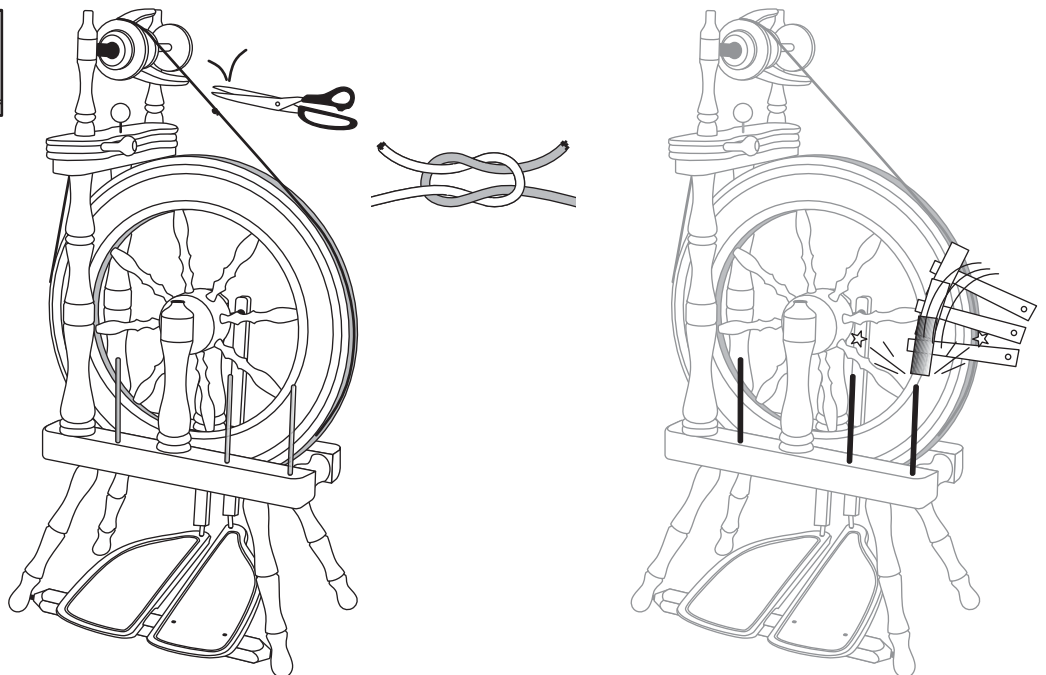
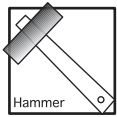

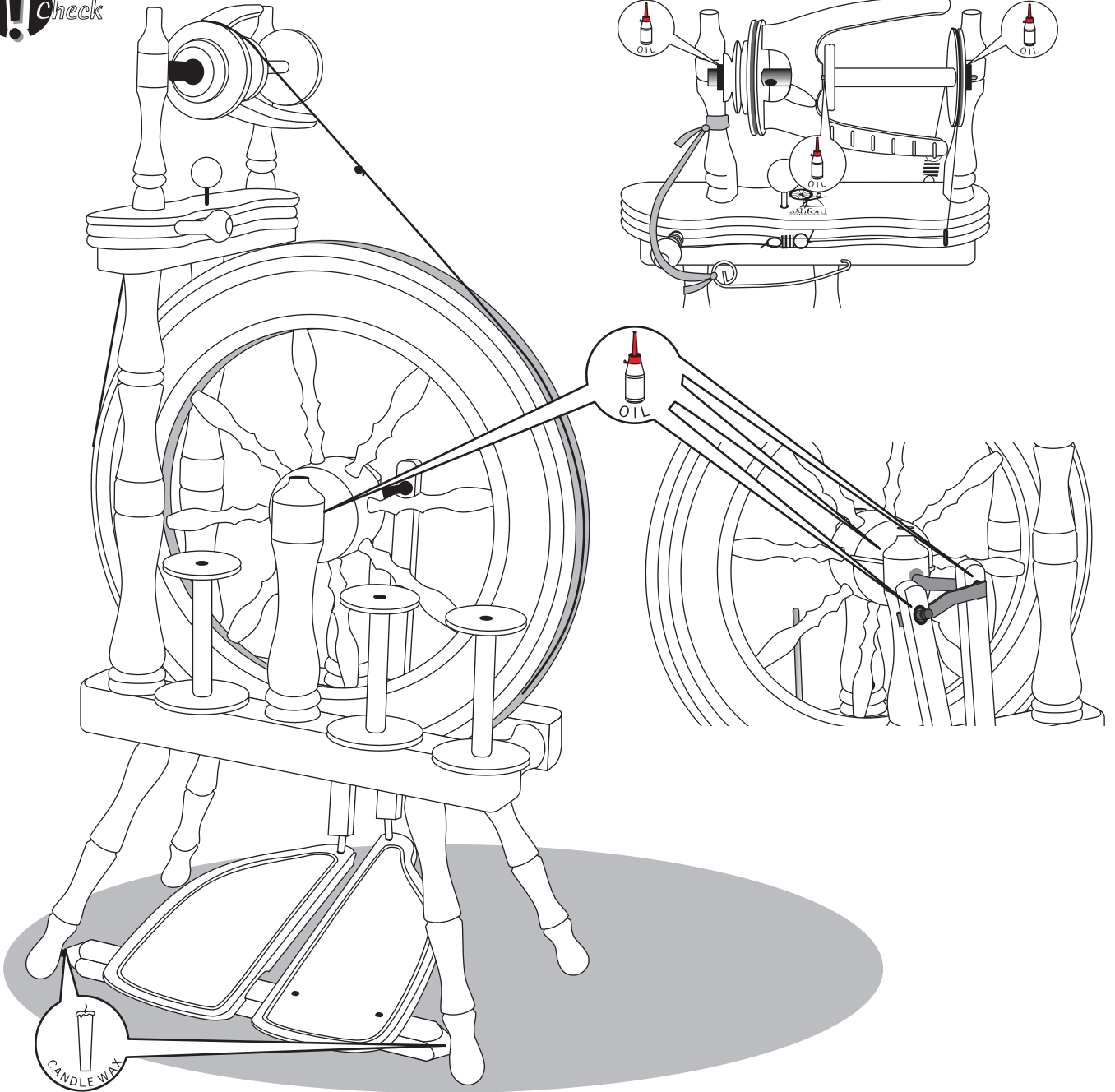

? WHY

Does not pull yarn in

Brake band tension is too loose.

1-2mm

Or →

Yarn breaks

Brake band tension is too tight.

1-2mm

Or →

Hard to Treadle

OIL

OIL

CANDLE WAX

CANDLE WAX

Or →

Drive band falls off easily

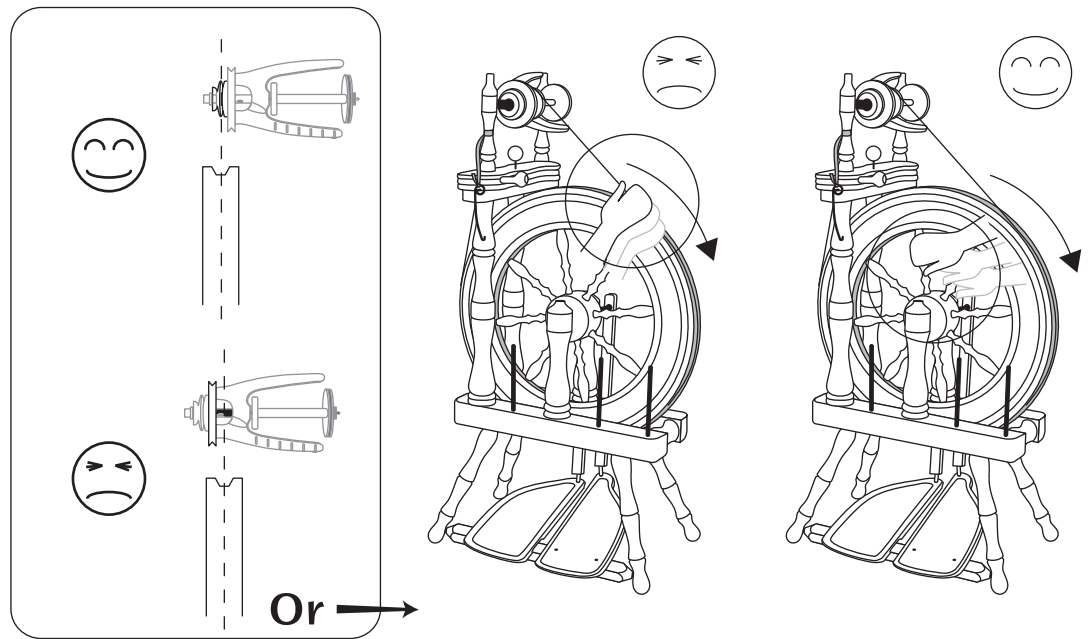

Strange sounds

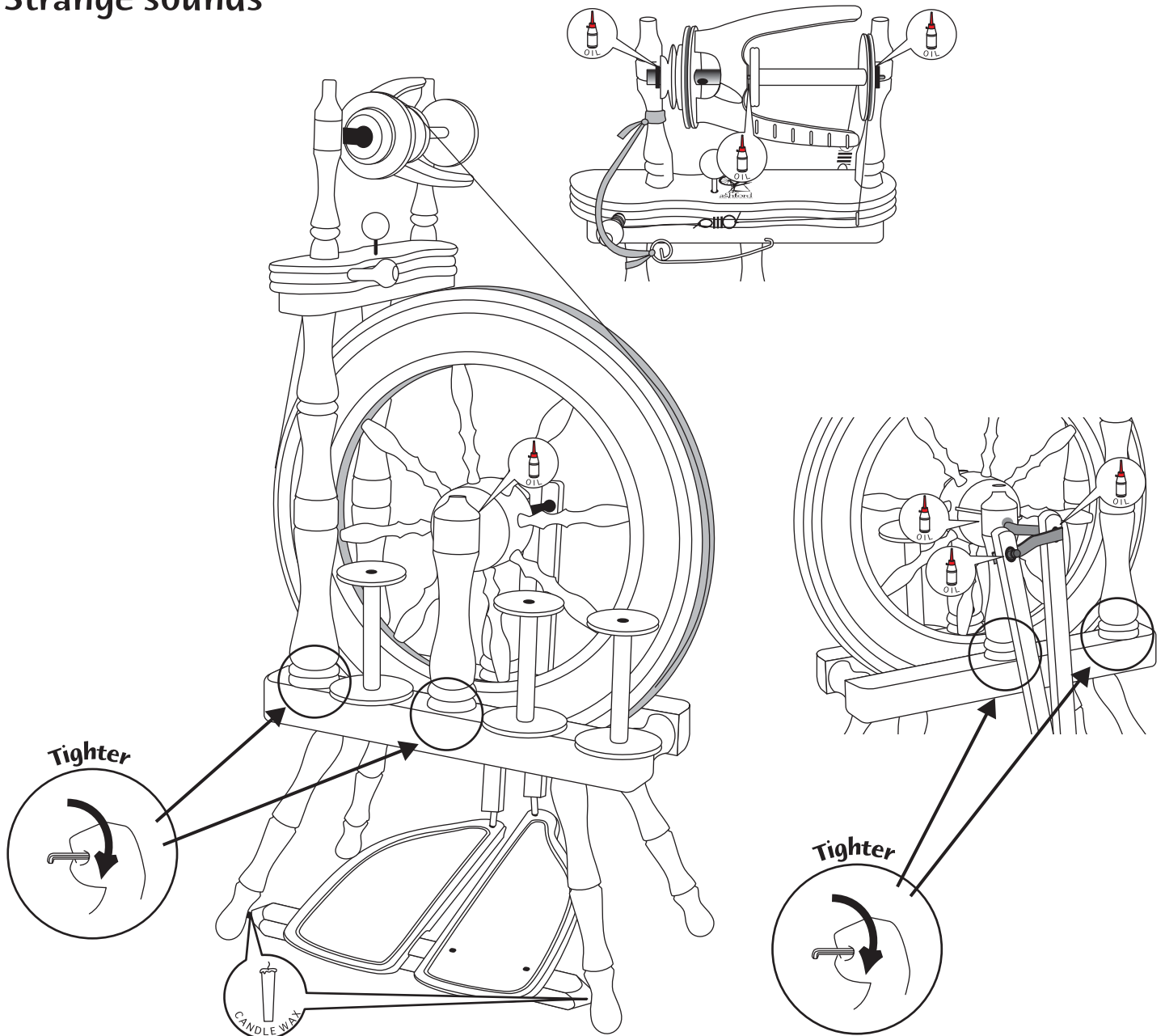

Real Scale Hardware Samples

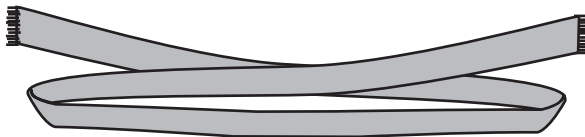
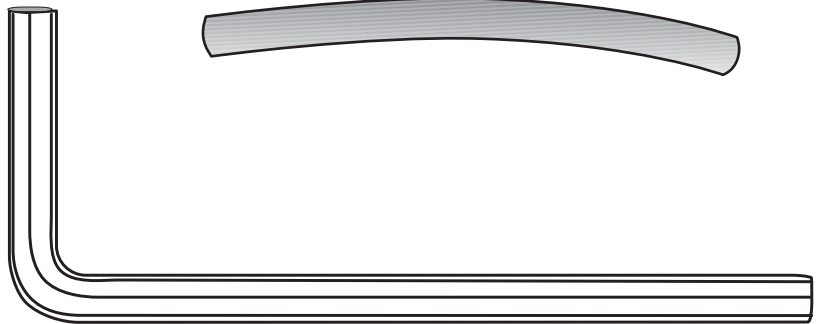
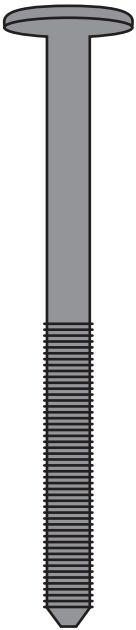
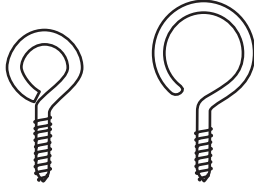
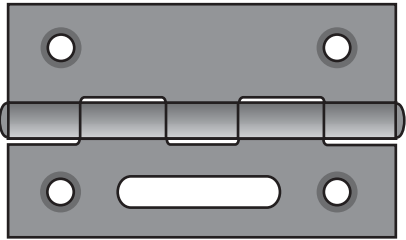
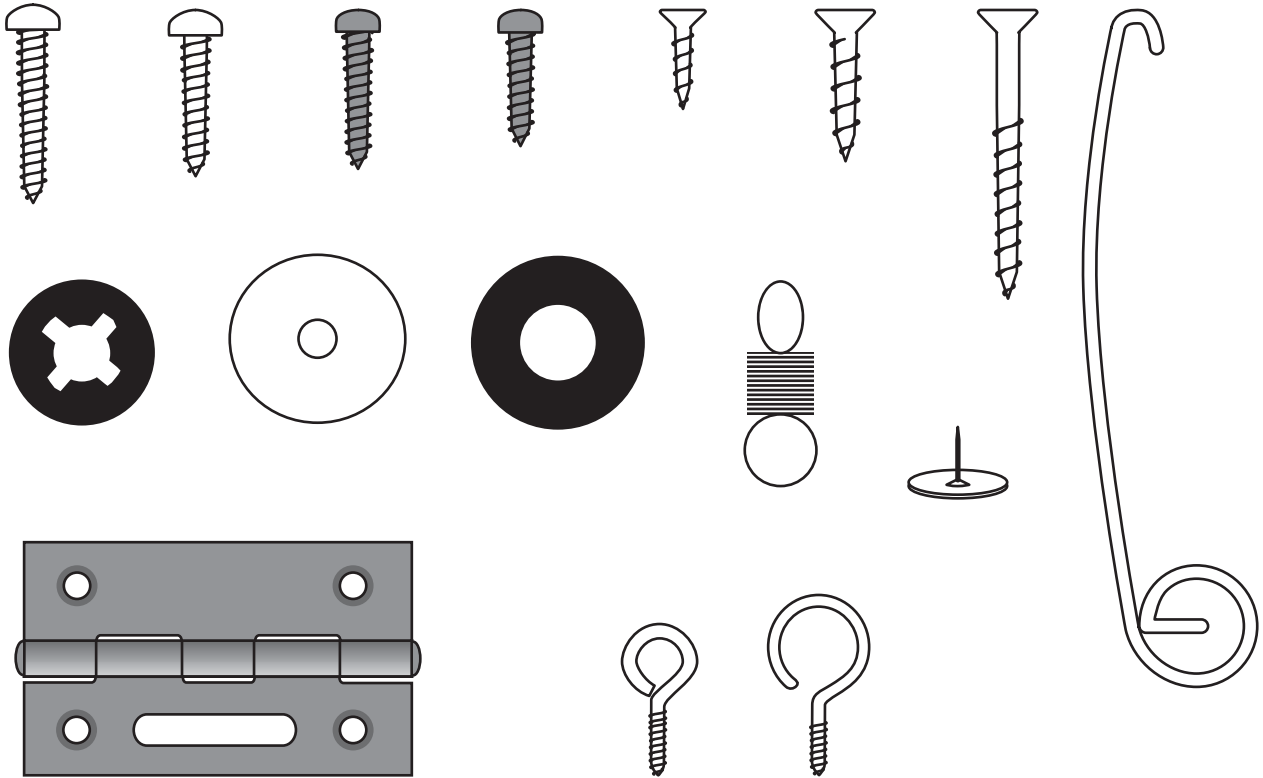

Meaning of Symbols

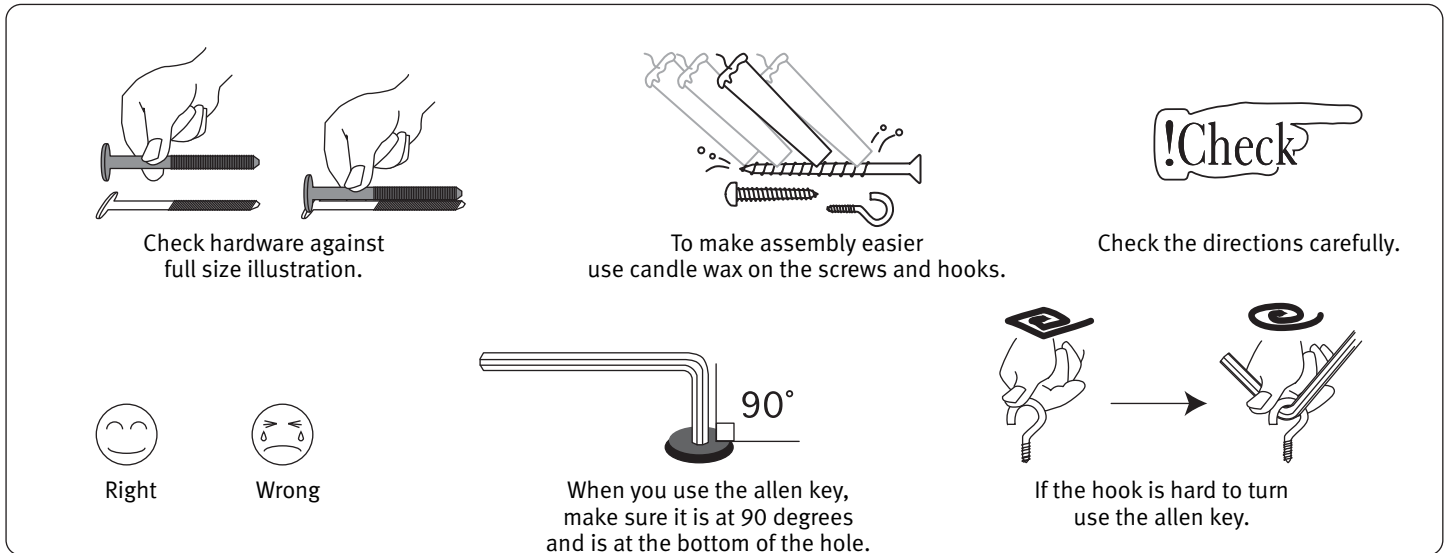

Assembly Instructions

Ashford Traveller Spinning Wheel - Single Drive -

Before Commencing - Read the instructions completely, identify the parts and note the assembly sequence.

Finishing the Wood - We recommend that the wood surfaces be waxed before assembly. This protects the kiln dried wood from climatic changes and enhances the beauty of the wood.

For the Ultimate Finish - Use the natural Ashford Wax Finish. The Silver Beech Tree is a native of New Zealand and has a lovely variety of colour and grain. The Ashford Wax Finish will enhance the natural colours and beauty of the wood. Ashford Spinning Wheels are also available factory finished in clear lacquer.

1. Thread 12 hooks into the flyer.
2. Secure the 2 hinges to the maiden bar. Note the position of the slot in the hinge.
3. Assemble the flyer unit. Check the shape of the nylon bearing on each maid upright, then insert into the correct hole. Insert the drive belt adjusting knob into the maiden bar, turn until the end just protrudes.
4. Check the angle of nylon bearing and then secure the maid uprights with screws and washers. Do not overtighten. The maid uprights may be twisted to remove the bobbin.
5. Place a bobbin on the flyer and the flyer into the bearings. Thread the screw eye into the side of the maiden bar, and screw hook into the opposite side.
6. Attach the brake band. Thread it through the screw eye and then tie the springs as illustrated.
7. Put the brake band over the grooved end of the bobbin. Do not over stretch springs.
8. Note the holes in the base for the maiden bar supports are on the left hand side.
9. Wax the steel rods in the treadle rail.
10. Locate the treadle rail into the holes in 2 legs. Check the treadle rail rotates freely. Then tap these legs to the bottom of the holes.
11. Tap the other legs to the bottom of the holes.
12. Secure the 4 legs with screws.
13. Turn the base and legs over.
14. Note the hole in one wheel support is right through. This is the rear support.
- 15,16. Secure the front and rear wheel supports with bolts and barrel nuts. These will be tightened after the next step.
17. Check the alignment of the holes for the crank.
18. Tighten the bolts from underneath.
19. Secure the nylon rods into the bottom of both connecting rods with screws. Place washer and connecting rod onto crank shaft and secure with O ring.
20. Place the wheel in position and insert the crank shaft. Align the second hole in the crank shaft with the groove of the hub. Check the wheel is parallel in the centre of the base and the wheel supports are tight against the hub. If not, loosen the bolts, adjust the wheel supports and retighten.
21. Rotate the hub pin until it is a firm fit in the slot in the hub. Then tap the hub pin through the hub and crank.
22. Insert the other ends of the nylon rods through the treadle rails until 15mm gap is left. Then secure both rods with a screw.
- 23, 24. Secure the maiden bar supports with bolts and barrel nuts.
25. Secure the top rail to the maiden bar supports with screws.
26. Secure the flyer unit to the top rail with 2 screws. These will be tightened shortly. Move the flyer unit until the wheel and middle flyer pulley are aligned, then tighten the screws. Position the drawing pin directly beneath the drive band adjusting knob to prevent it marking the wood.
27. Tie the threading hook to the front maid upright with tape.
28. Ratios - You may find it easier to spin a finer yarn if your flyer rotates faster. To change ratio simply move the drive belt to a smaller flyer pulley and retension the drive belt.
29. Check the end of the adjusting knob is not protruding beneath the maiden bar. Then place the drive belt around the wheel and large flyer pulley.
30. Tie drive belt and cut off the extra. Tap the steel lazy kate pins into the base.

CHECK!

Oil all points on the Spinning Wheel before use as per diagram.

各マークの意味

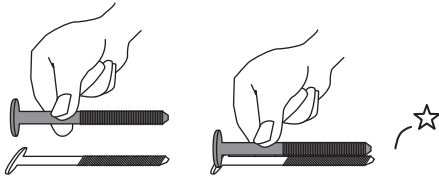

説明書表示のねじ類は全て実物大です。
実際にあわせて確認して下さい。

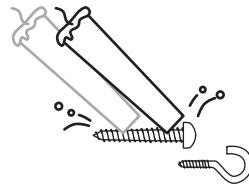

ねじ類にろうを塗っておくと
楽にねじが回せます。

!Check

その部品の形や、
向きに注意して下さい。



良い



だめ

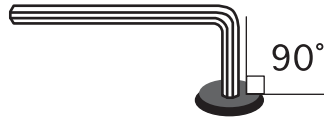

六角レンチは直角にしてください。

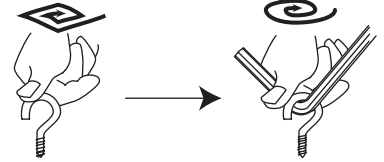

レンチを使うと入れやすいです。

アシュフォード・トラベラー シングルドライブ (スコッチテンション) の組み立て方 (組み立て説明書の図を見ながらお読み下さい)

◎組み立てる前に、この説明書の図と実際の部品の形を照らし合わせておくと、より簡単に組み立てることが出来ます。

◎気候の変化や乾燥から木材を守り、良い状態を長く維持するために組立前の塗装をお勧めします。塗装には是非、アシュフォードのワックスキットをお使い下さい。布ですりこむだけでもとの美しい木肌を隠さず、きれいに仕上がります。むらにもなりません。

- [1] フライヤーの表と裏にフックをねじ込みます。
- [2] 蝶番をフライヤーの台の上に取り付けます。
- [3] 方向に注意して、フライヤー支柱を差し込みます。ドライブベルトの張りを調節するテンションノブを取り付け、先が下から出っ張らない程度まで回します。
- [4] 支柱の黒いナイロン軸受けがお互いに平行になるよう調節し、台の裏からねじで留めます。支柱を握り、力を入れて回るくらい少しゆるめに止めておくとフライヤーの取り外しが楽です。輪型の金具を台にねじ込みます。
- [5] フライヤーにボビンを入れ、フライヤーの台に取り付けます。ボビンの方向に注意して下さい。フックを【4】で輪型の金具を取り付けた裏面にねじ込みます。
- [6] ブレーキバンドを取り付けます。スプリングをブレーキバンドに結ぶ前に、輪型の金具を通すことを忘れないようにしましょう。
- [7] ブレーキスプリングがのびない程度の張りにして、フライヤーにブレーキバンドをかけます。
- [8] 本体に足を付けます。足の前後に注意して下さい。図中「!」印の穴を左側にして置いた場合、向こう側にペダルを付ける足（穴があいている）が入ります。
- [9] ペダルの両脇の金属の部分にろうを塗り、足の穴に差し込み、本体に差し込みます。
- [10] ペダルの入っている穴がずれてしまわないように注意しながら、交互に少しずつ打ち込んでゆきます。
- [11] 後ろ足を打ち込みます。穴の最後までキチッと打ち込んで下さい。
- [12] それぞれの足をねじで留めます。
- [13] 表を向けます。
- [14] はずみ車の支柱の違いを確認します。
- [15] 穴の突き抜けていない支柱を手前（ペダルの付いている足側）、
- [16] 穴の突き抜けている方を奥にして、お互いのナイロンベアリングが向かい合うように仮留めします。

- [17] 穴がお互いに真正面を向くように調節します。
- [18] 位置が決まったら、【16】で仮留めしたボルトをしっかりと締めます。六角レンチを使うときは、ねじの穴に垂直に、奥まで差し込んで回しましょう。ねじ山が壊れてしまうと回らなくなってしまうので大変です。
- [19] もしもクランクシャフトの回りが悪いときには、ペンなどの細いものを使い、図のようにベアリングを動かして2つのベアリングの穴の方向を調節します。ベアリング部分には油を差して下さい。
- [20] コンロッドジョイント (1.) をそれぞれのコンロッドにネジで取り付けます (2.)。クランクシャフトに、ワッシャー (3.) とコンロッドを通し、リング (4.) で留めます。
- [21] はずみ車を取り付けます。この時に口を塗っておくと楽に入ります。はずみ車の芯の切れ目にクランクシャフトの2番目の穴を合わせます。
- [22] ハブピンをたたき込みます。
- [23] コンロッドにペダルを取り付けます。ペダルとコンロッドの間は15mm程度開けて留めます。
- [24] 筒型ナットが入る穴を内側にして、フライヤーの台が乗る支柱を取り付けます。
- [25] ボルトをしっかりと締めます。
- [26] フライヤーの下台を差し込み、ねじで留めます。
- [27] フライヤー台の裏に取り付けた蝶番とフライヤーの下台を、まず仮留めし、はずみ車の位置が、フライヤーの溝とボビンの溝の真ん中に一直線になるように調節してからねじを締めます。
- [28] 回転する部分にほんの少しの油を付けます。引き出しフックを使いやすい場所に結びます。
- [29] ドライブベルトをかける場所によって回転比を変えることができます。ベルトをかけ替えるときはフライヤーの台の位置も調節し(【27】)して下さい。
- [30] フライヤーの台が傾いていないのを確認して、ドライブベルトを取り付けます。ドライブベルトの張り(糸の引き込み具合)は、紡ぎながらテンションノブを使って調節します。
- [31] 余ったドライブベルトを切り、ボビン立てになる鉄棒を金槌で打ち込みます。

【注】 しばらく使っていて、回りが悪くなってきたり、変な音がし始めたら油の差し時です。ペダルの両側は、シミにならないように口ウを使って下さい。

本製品は天然木製品ですので、時の流れや、気候などの条件で木の状態が変わってきます。ボルトを締め直すときのために、付属の六角レンチはなくさないようにとっておいて下さい。